 - User manual

Safety Notices

The device complies with regulations and standards in force in the Czech Republic and the European Union. The device has been tested and is supplied in working order. To keep the device in this condition, it is necessary to adhere to the following safety and maintenance instructions.

Using the device in a manner other than prescribed by the manufacturer may cause its safeguards to fail!

The power supply outlet or disconnection point must be freely accessible.

The device must not be used in particular under any of the following conditions:

- The device is noticeably damaged
- The device does not function properly
- Unfastened parts can move inside the device
- The device has been exposed to moisture or rain
- The device has been serviced by unauthorized personnel
- The power adapter or power supply cable are noticeably damaged
- If the device is used in a manner other than designed for, the protection provided by the device may fail.
- The local electrical system must include a power switch or a circuit breaker and overcurrent protection.

The manufacturer warrants the device only if it is powered by the supplied power adapter or an approved power supply.

If you have any problems with installing or operating the device, please contact the technical support:

HW group s.r.o.

<http://www.hw-group.com>

email: support@HWg.cz

Formanská 296

Prague, 149 00

Phone: +420 222 511 918

Before contacting technical support, please have at hand the exact type of your device (at the type plate) and, if known, the firmware version (see later in this manual).

Table of Contents

NB Devices product family	4
Overview of NB Devices	4
Shared features of the NB-IoT product family	4
Measurements and data upload	4
Description of HW elements	7
Setting up the device	7
Migration of connected device	12
Portals where can be devices connected to	14
SensDesk.com portal features	15
NB-Devices models and their specific features	17
NB-2x1Wire	17
NB-2xIN	18
NB-WLD	19
NB-2xOUT	20
Technical specifications	20
Mechanical dimensions	22

NB Devices product family

NB Devices is a family of environment monitoring products that use the Narrowband (NB-IoT) mobile network. All products feature robust design, battery-powered operation, and seamless integration with the SensDesk IoT portal. All devices include a 3V alkaline CR123A battery that allows continuous operation for about 3 years (depending on the device type, application and connected sensors).

Overview of NB Devices

- **NB-2x1Wire** – A device for connecting thermometers, hygrometers, or other sensors via the 1-Wire bus. Allows connecting two 1-Wire or 1-Wire UNI sensors to measure up to 4 quantities simultaneously.
- **NB-2xIn** – A device for connecting a door or window contact, a PIR motion detector or a smoke or gas detector with a dry contact output. Allows connecting 2 independent detectors. Inputs can feature pulse counters for connecting energy meters with SO output; however, external power is needed for reliable deployment.
- **NB-WLD** – Water leak detector with a moisture-sensing cable. Allows connecting 1 sensing cable of up to 60m length.
- **NB-2xOut** – A module with 2 relay outputs controlled from the SensDesk portal over the NB-IoT network.

Shared features of the NB-IoT product family

- Robust metal design, 67×78×33mm
- External antenna, SMA connector
- 4FF (nano SIM) holder
- LED indicator
- Plug&Play – connect power or remove the insulating strip and the device is immediately available in the portal
- All settings (data upload period, safe ranges) are configured in the portal
- Battery state appears in the portal as another sensor
- Powered from a 5V adapter or the built-in replaceable CR123A battery

For specifics of individual devices, including any differences in the measurement period, battery life and so on, see the respective device page.

Measurements and data upload

Measurement and data upload period

The period for logging the measured values and uploading them to the portal is configured automatically via the portal, separately for operation with an external power source and

battery-powered operation. At the time of this writing, the following values were valid for the SensDesk portal:

External power

- Logging period (measuring, storing values in the internal memory): 5 minutes
- Data upload period (connecting to the portal and uploading all logged values): 1 hour
- Check period (NB-2xOUT brief query for output state changes): 10 minutes

Battery power

- Logging period (measuring, storing values in the internal memory): 15 minutes
- Data upload period (connecting to the portal and uploading all logged values): 10 hours
- Check period (NB-2xOUT brief query for output state changes): 1 hour

Only the server administrator may change these periods. In justified cases, individual changes can be agreed with the server administrator. However, keep in mind that if the periods are shortened, battery life may be very negatively impacted. In any case, the data upload period cannot be shorter than 60 minutes and the logging period shorter than 5 minutes.

Periodic and non-periodic reading of sensors

Sensors values are regularly read in the fixed Log Period, which is configured via the SensDesk portal. However, in addition to the periodic reading, the values can be also read if the following happens:

1. The device is powered up by connecting the battery or an external power supply
2. The button is pressed
3. If the SafeRange is exceeded at the moment of periodic reading, the measurement is repeated after the Delay interval

Periodic and non-periodic data upload

Sensor values are uploaded to the server periodically in the fixed period, which is configured via the SensDesk portal. However, in addition to the periodic upload, data can be also uploaded if the following happens:

1. SIM card is inserted
2. Device power is connected or changed
3. The button is pressed
4. SafeRange is exceeded (if the Delay is set, then only after the Delay elapses)

SafeRange – range of allowed values

SafeRange is configured in the SensDesk portal separately for each sensor. Whenever the measured value is outside of this range, a message is sent. (However, keep in mind that in order to extend battery life, sensors are only read in the Log period. With the exception of SD-2xIN, sensors are NOT read at other times.) If a Delay is set together with the SafeRange, the repeated measurement is performed at the next Log period, and an Alarm is raised only if the repeated measurement is also out of the SafeRange.

Hysteresis / Idle range

The Hysteresis setting defines a tolerance band for suppressing alarm alerts. The function prevents multiple alarm alerts if the reading oscillates around the specified threshold. The range is configured independently for each sensor.

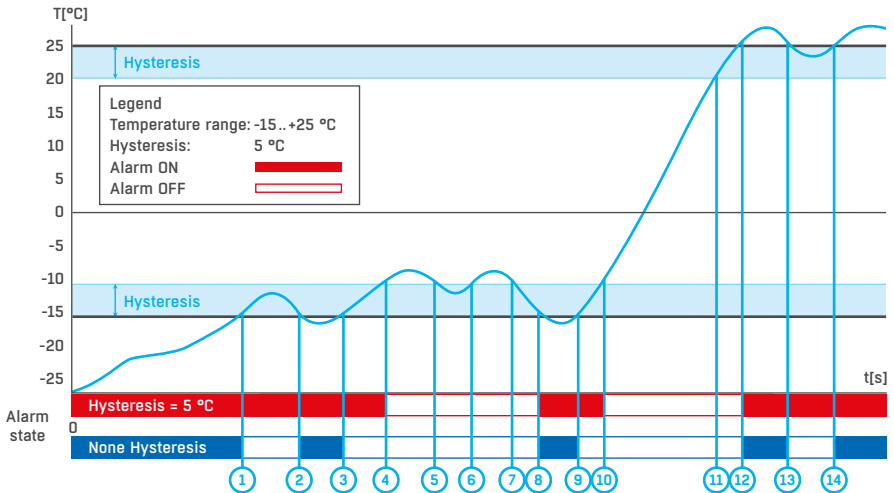

The figure demonstrates two cases. Without the hysteresis idle range of 5 °C, the alarm raised in point 8 would end in point 9; however, the hysteresis function keeps the alarm active until the temperature reaches the upper limit of the tolerance band (point 10): $5\text{ °C} + (-15\text{ °C}) = -10\text{ °C}$.

- **Hysteresis = 5 °C** – The unit sends **3 e-mail (SMS) messages**. Alarm active in points **0..4, 8..10, 12 and beyond**.
- **No hysteresis (0°C)** – The unit sends **8 e-mail (SMS) messages**. Alarm active in points **0..1, 2..3, 8..9, 12..13, 14 and beyond**.

In determining when the Alarm ends, the Hysteresis value applies. The end of an Alarm is only notified when the measured value is well within the SafeRange. However, the value is only read according to the Log Period.

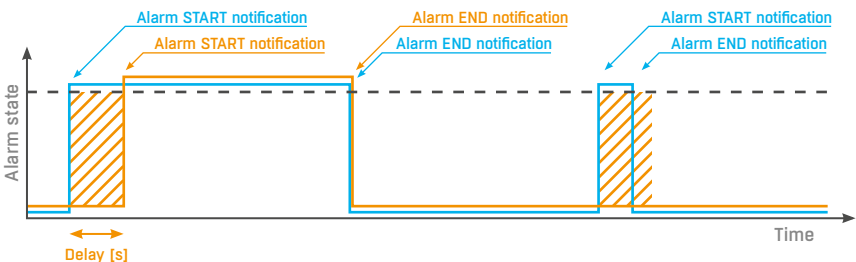

Alarm status notification based on a Delay value:

- **Blue:** Delay = 0
- **Yellow:** Delay is non-zero

To increase battery life, be careful when setting the SafeRange and Hysteresis values.

Description of HW elements

LED indicator (Status)

The blue LED gives a quick status indication for debugging and troubleshooting. It can indicate these states:

- Short flash – reading of sensors and inputs
- Rapid flashing – registration to the NB-IoT network
- Continuously on – communication over the NB-IoT network, data transfer

When power is connected to the device, the indicator briefly lights up to indicate modem initialization and 1-Wire sensor detection. Then, it quickly flashes as the device connects to the network, and lights up whenever the device communicates with the portal. It also briefly flashes when the 1-Wire sensors or the WLD cable state are being read.

Setup button

The button is used to send values to the portal immediately and to detect sensors.

- Press – sensors are detected and data are sent to the portal
- Press for longer than 10 s – reset to factory defaults

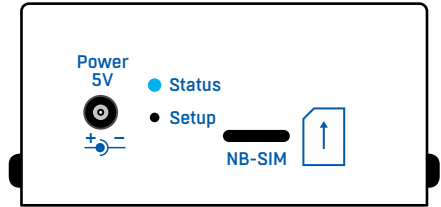

Setting up the device

- 1) Attach the external antenna
- 2) Connect 1-Wire sensors (NB-2x1Wire only)
- 3) Insert SIM card
- 4) With a slight force, pull out the insulating strip that insulates the battery from the contacts
- 5) Connect the external power supply and wait until the device connects to the operator's network (i.e. until the blue LED turns off). Depending on the network and device configuration, this can take up to 20 minutes (when the device is first connected to an operator's network, including in a new country or region). During this time, do not disconnect external power to avoid battery drain.
- 6) Default portal where are devices connected is www.HWg-cloud.com.

To install new device are 2 options:

- a) You have **existing account** on the **HWg-cloud** and you would like to **adopt** new device to this one account. (See page 8)
 - b) You have existing account on **another SensDesk technology based portal** (www.SensDesk.com or www.HWportal.cz for example) and you would like to **migrate** new device to this one account. (See page 9)
- 7) Define sensor name & SD SafeRange for each sensor. (See page 11)

6a) Adopt new device to HWg-cloud.com

Open the www.HWg-cloud.com website, login to your account and go to the **My Team** page.

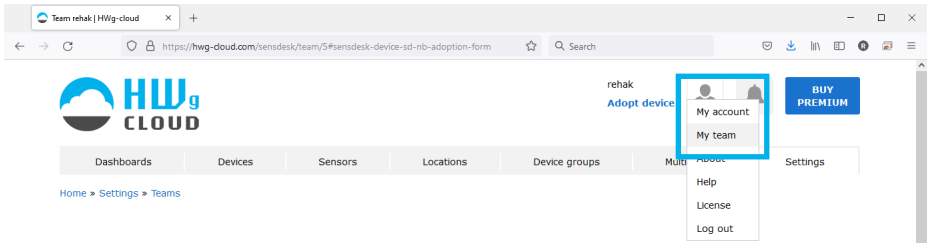

Scroll down to the **Device Adoption**.

Fill the device hash (1234-5678 number on the label of physical device)

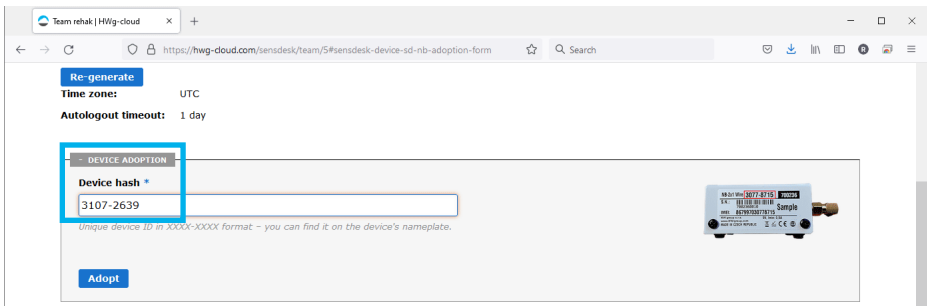

Device will appear after some time in the devices:

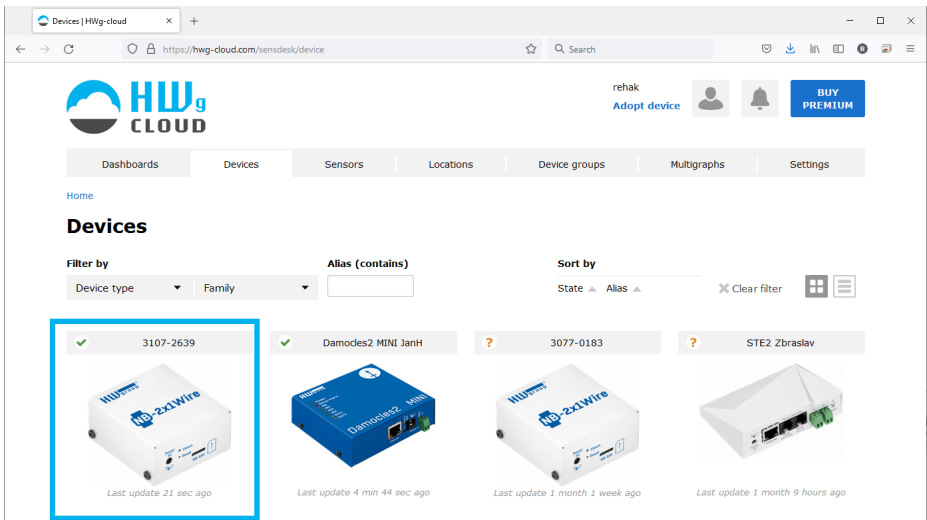

6b) Migrate new device from HWg-cloud.com to another portal

Open the www.HWg-cloud.com website, click to **Set Device** button on the top of the page.

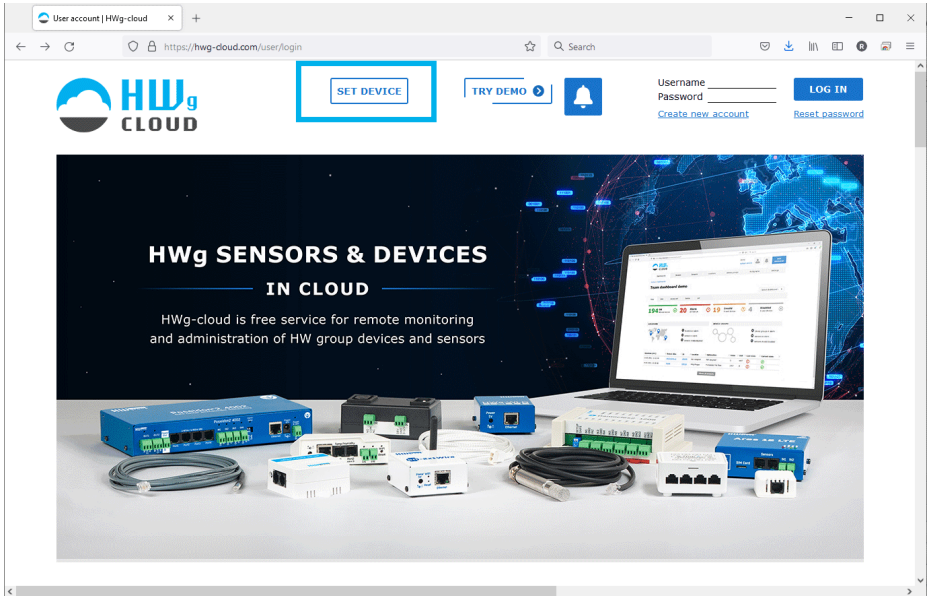

Fill the device hash (1234-5678 number on the label of physical device)

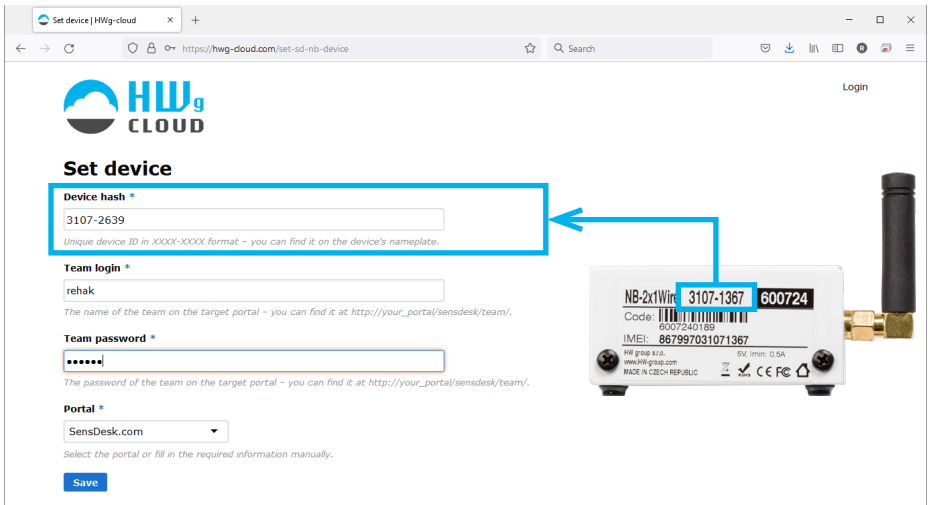

As **Team login** & **Team password** fill data from the SensDesk technology based portal, where you have the account. You will find them on the Team page.

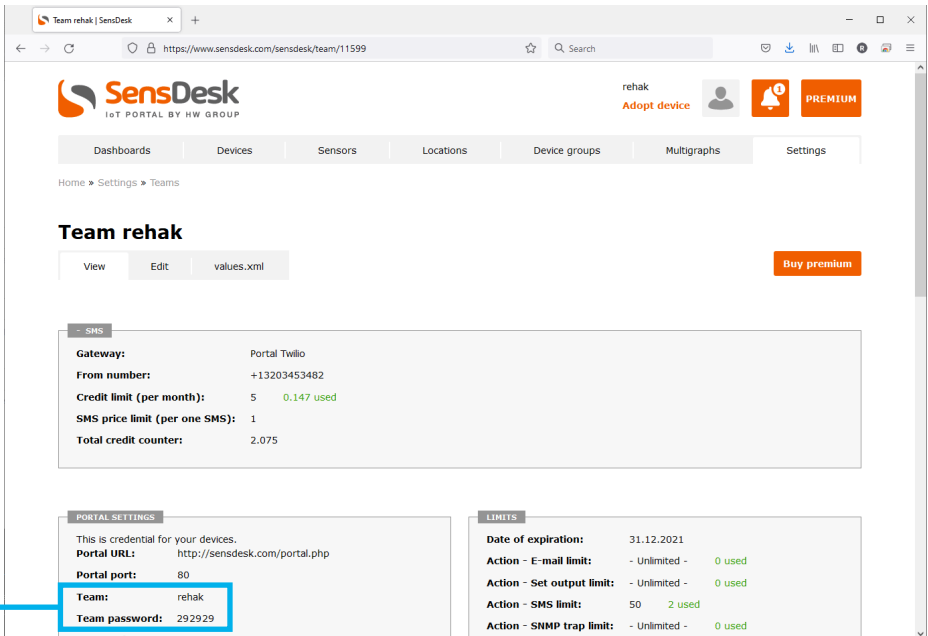
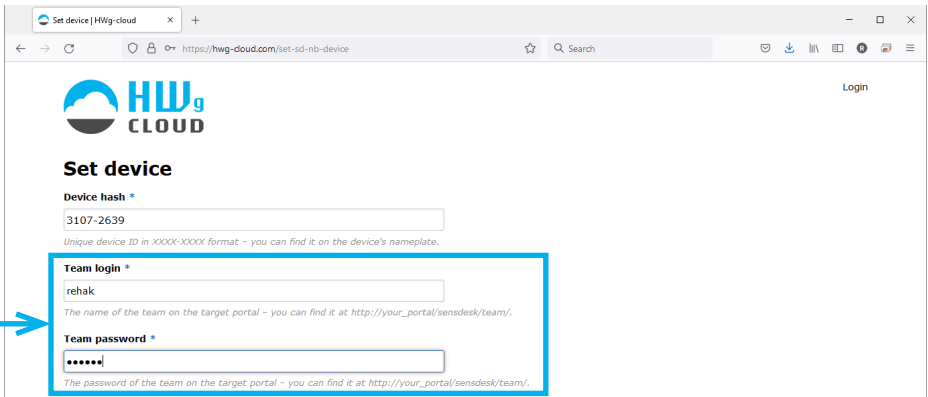

After you click to **Save** button on the web page, take a pencil or other tool and briefly **press the Setup button on the device**. It will start blinking (communication with the portal) and finalize device migration process.



Setup button

Device will appear in the Device list:

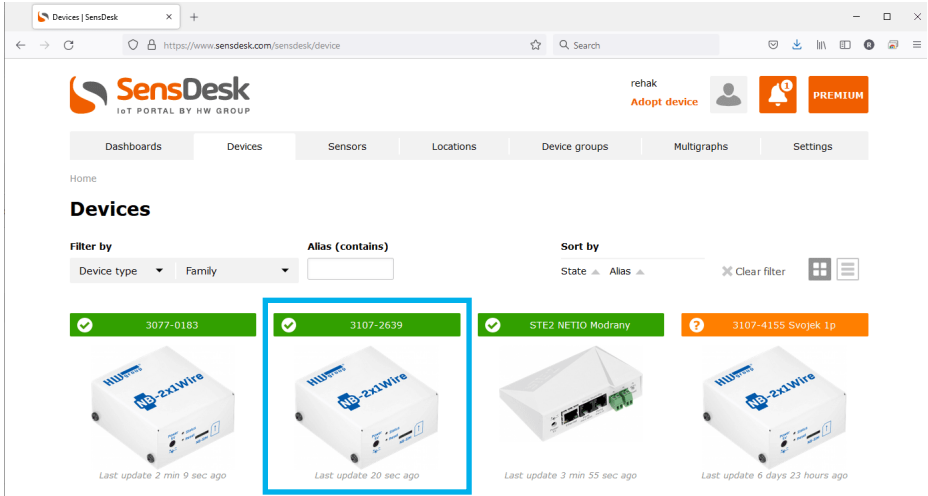

7) Define sensor name & SD SafeRange for each sensor

Part of the device installation is to define sensor name & SD SafeRange for each sensor. Define SD SafeRange to significantly speed-up alerts when sensor value oscillate around the SafeRange limit.

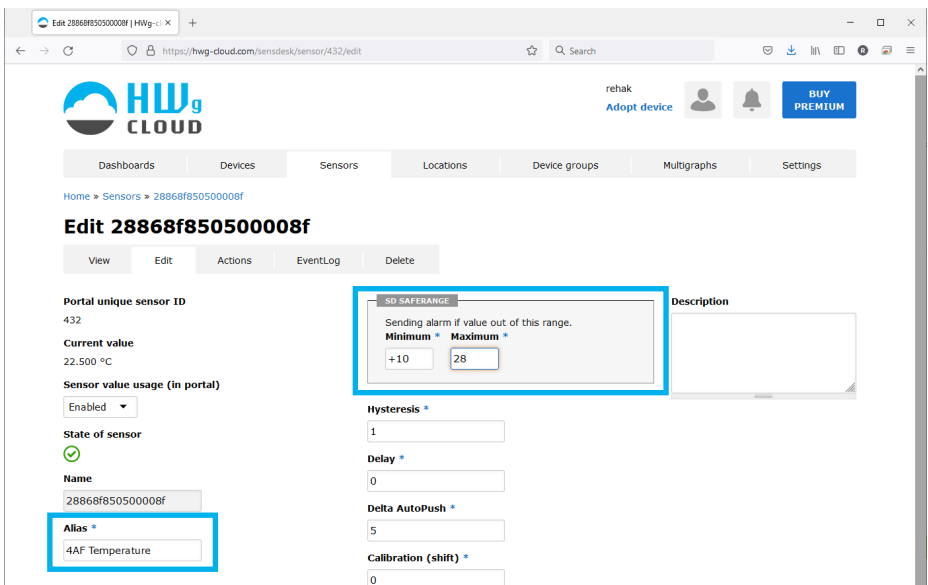

Migration of connected device

Connected and working device can be also easily migrated from one portal to another. For example in this case from paid portal www.SensDesk.com to free www.HWg-cloud.com.

The screenshot shows the SensDesk IoT Portal interface for a device with ID 3107-2639. The page includes a navigation menu with options like Dashboards, Devices, Sensors, Locations, Device groups, Multigraphs, and Settings. The device details section shows a status of 'Adopt device' and 'PREMIUM'. A red box highlights the 'IP Address: 0.0.0.0' field, with a blue callout box below it containing the text 'Migrate device to another SensDesk technology based portal'. Below the details are three gauge charts: '28868f950500008f' showing a temperature of 22.649 °C, 'Battery 3107-2639' showing a battery level of -1 %, and 'Network Quality 3107-2639' showing a network quality of 3 %.

Fill Team login and Team password, choose the right SensDesk technology based portal.

The screenshot shows the 'Migrate device' form in the SensDesk IoT Portal. The form includes the following fields and options:

- Device hash ***: 3107-2639
- Team login ***: rehak
- Team password ***: [Redacted]
- Portal ***: HWg-cloud.com

Below the form is a 'Save' button. The page also includes a navigation menu and a user profile section with 'Adopt device' and 'PREMIUM' labels.

After you click to **Save** button on the web page, take a pencil or other tool and briefly **press the Setup button on the device**. It will start blinking [communication with the portal] and finalize device migration process.

The screenshot shows the SensDesk portal interface for device 3107-2639. The top navigation bar includes 'Dashboards', 'Devices', 'Sensors', 'Locations', 'Device groups', 'Multigraphs', and 'Settings'. A notification states 'Configuration saved. Restart the device or wait for the device to log on.' Below this, the device name '3107-2639' is displayed with a 'View' button. A table of actions includes 'Edit', 'Edit sensors', 'Actions', 'EventLog', 'Delete', and 'Debug'. The device status is 'Last log: 18.09.2021 02:06' with a green checkmark. Other details include 'Device groups: Not assigned', 'Location: Not assigned', and 'IP Address: 0.0.0.0'. A 'Migrate to a paid service' link is present. To the right is an image of the HWg NB-2x1Wire device. Below are three gauges: '28868f850500008f' (22.625 °C), 'Battery 3107-2639' (-1 %), and 'Network Quality 3107-2639' (2 NQ). Each gauge has a 'SAFE RANGE' and a 'Last update' timestamp.

Device will appear on the target portal.
Only sensor names will be transferred between the portal. No more device configuration or data history!

The screenshot shows the HWg Cloud portal interface for the 'Devices' section. The top navigation bar includes 'Dashboards', 'Devices', 'Sensors', 'Locations', 'Device groups', 'Multigraphs', and 'Settings'. The user 'rehak' is logged in with an 'Adopt device' button. The 'Devices' section is active, showing a list of devices. The list is filtered by 'Device type' (Family) and sorted by 'State' (Alias). The devices listed are: '3107-2639' (HWg NB-2x1Wire, last update 21 min ago), 'Damodes2 MINI JanH' (Damodes2 MINI, last update 4 min 44 sec ago), '3077-0183' (HWg NB-2x1Wire, last update 1 month 1 week ago), and 'STE2 Zbraslav' (last update 1 month 9 hours ago). The first device, '3107-2639', is highlighted with a blue border.

Portals where can be devices connected to

NB Devices have to be connected to some online Portal **based on SensDesk technology**.

- 1) www.HWg-cloud.com is free portal provided by manufacture with limited functions.
- 2) www.SensDesk.com is paid portal provided by manufacture.
- 3) **Portal providers** are independent companies running their own compatible portals. List of them is on the main page of www.HWg-cloud.com.



HWg-cloud.com
HWg sensors & devices in cloud

HWg-cloud.com

- Free service
- Up to 20 devices
- Device management



SensDesk
Monitoring and Alerting system in cloud by HW group

SensDesk.com

- Paid service
- Subscription plans
- SMS, Voice calls, graphs

Portal providers

Do you need advanced features?

SensDesk.com is comprehensive professional system for remote monitoring of your environment.

- Higher device or user limit
- Advanced alerts (SMS, Phone-calls)
- Look further in history (more log DB)
- Integration into 3rd party system (Open API)
- Reports in PDF

Portal providers

Global:	SensDesk.com	HWgroup.s.r.o	Netherlands:	SensDesk.nl	MCS.N.V.
Austria:	SensDesk.at	DellEquip GmbH	Luxembourg:	SensDesk.nl	MCS.N.V.
Belgium:	SensDesk.nl	MCS.N.V.	Romania:	SensDesk.ro	Simco Systems s.r.l.
Czech Republic:	HWportal.cz	HWserver.s.r.o	Switzerland:	SensDesk.ch	INSERTO.AG
France:	SensDesk.fr	QL3D	Latvia:	SensDesk.lv	Baltic Project Group SIA



SensDesk.com portal features

Graphs of values



SMS & Voice call alerts

The screenshot shows the SensDesk portal interface for configuring an action on a sensor. The page title is "Actions on sensor Temperature local". The interface includes a navigation menu with options like "Dashboards", "Devices", "Sensors", "Locations", "Device groups", "Multigraphs", and "Settings". The main content area shows the configuration for an action on the sensor "Temperature local". A blue speech bubble highlights the "Action = Temp-VoiceCall" and "SMS" options. A red plus sign icon is visible in the bottom right corner.

Multigraph of several values

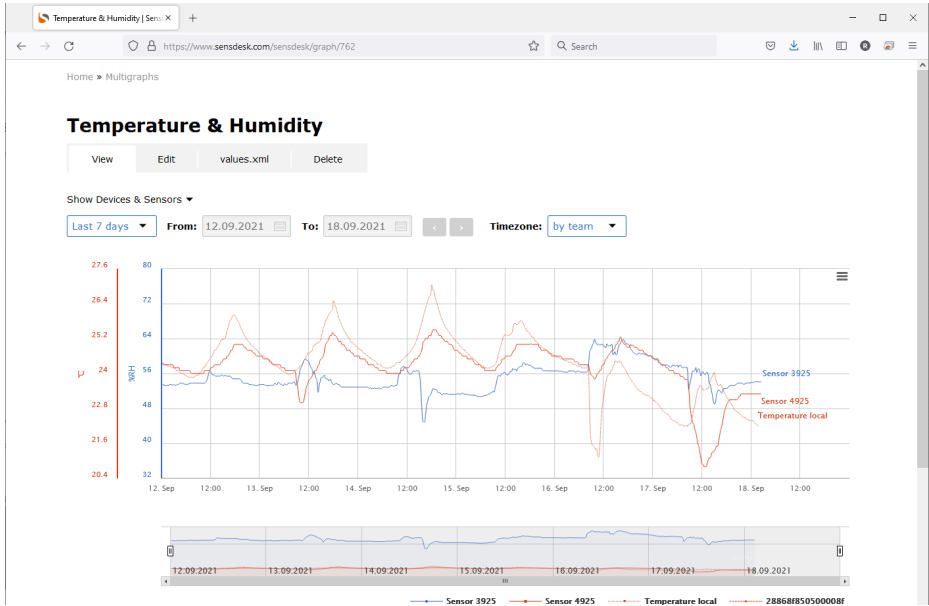

Other features & PDF reports

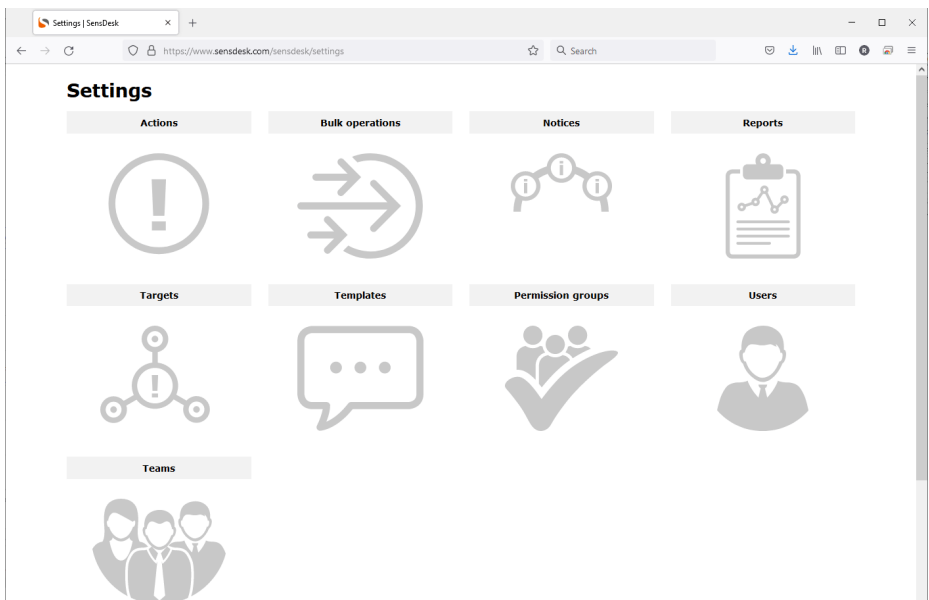

Open API (SNMP & XML)

Team rehak

View Edit values.xml

Team
https://www.sensdesk.com/sensdesk/team/11599/values.xml?values_xml_key=FNnRVH0v1Wn9IkznXkUUM17_ufZ0ppe7aZ3b0YohDck

User
https://www.sensdesk.com/sensdesk/team/11599/values.xml?values_xml_key=pudVwDxs3OeJxFEUK6_GhuU9Zwz9TgoUDMdh7ymAxa8

How to use values.xml
All sensor data for your Team with permission for your User can be accessed via XML over HTTP(S) for reading:

- Host - see above
- The values.xml download period is limited to 1x minute for each URL. We recommend to read it with 15 min period.
- There is no username & password, authentication is realized with the generated key parameter.
- User can provide limited data from the Team (defined by permission groups).
- XML structure will be updated with every new device connected to your team / user account.

NB-Devices models and their specific features

NB-2x1Wire

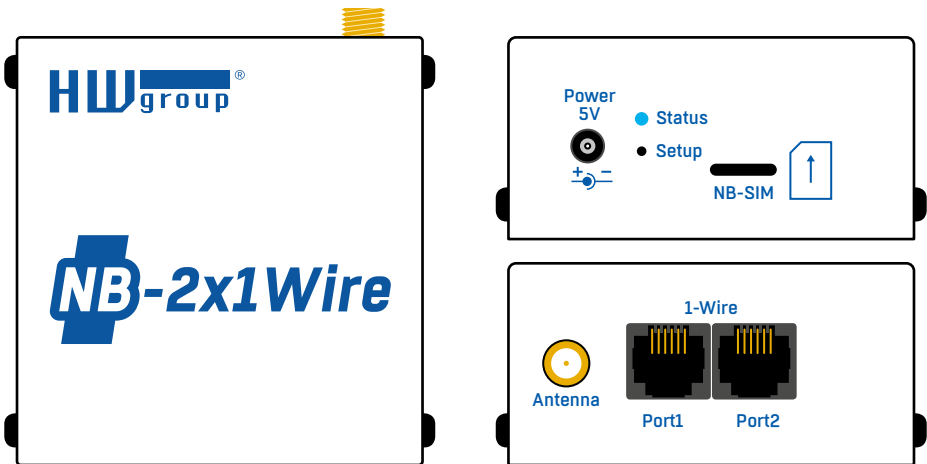

Measurement hub for connecting thermo-meters, humidity sensors or other sensors via the 1-Wire bus. Allows connecting two 1-Wire or 1-Wire UNI sensors (one per port) to measure up to 4 quantities simultaneously.

Sensors are detected whenever power is connected to the device or the Setup button is pressed.

The device can be powered from an external 5V adapter, from its internal battery, or using a combination of these. With a single connected Temp-1Wire IP67 temperature sensor and the default sensor reading and data upload periods, the battery lasts up to 3 years. When using 1-Wire UNI sensors, either the sensors or the NB-2x1Wire device should be powered from an external adapter because such sensors significantly reduce the battery life.

NB-2xIN

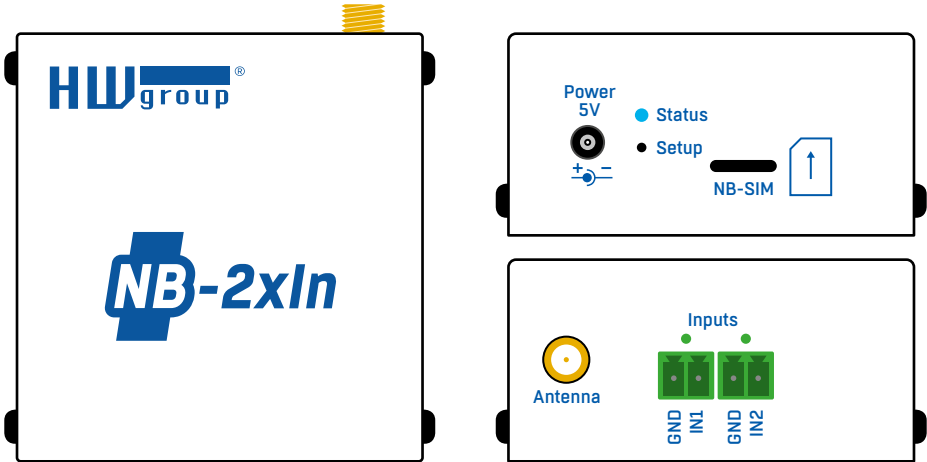

A device for connecting a door or window contact, a PIR motion detector or a smoke or gas detector with a dry contact output. Allows connecting 2 independent detectors. Inputs feature pulse counters for connecting energy meters with an SO output. **Due to high energy requirements of SO outputs, external power is required for reliable pulse counting.** Otherwise, reliable operation cannot be guaranteed.

The input mode (Alarms or Counters) can be changed in the digital input configuration at the SensDesk portal using the "Alarm level" parameter.

If the "Not Defined" option is selected, the input is in pulse counting mode and its state is only uploaded in the regular data upload period. Only changes longer than 20 ms are detected.

When Alarm level = 1 or Alarm level = 0, the input is in the Alarm mode. The input state is uploaded in the regular data upload period as well as whenever there is a change. To comply with the transmission limit, the device will send no more than 3 alarms per 10 minutes. Frequent state changes can have a significant impact on battery life. **For battery operation, cables should be as short as possible to avoid false pulses. For operation with an external power adapter, the cable should be at most 50 m long.**

The default mode is the counter mode (i.e. Alarm level = Not defined).

When an input is activated (contact closed) and the device is powered from an external adapter, the respective green LED lights up. The LEDs are inactive on battery power.

NB-WLD

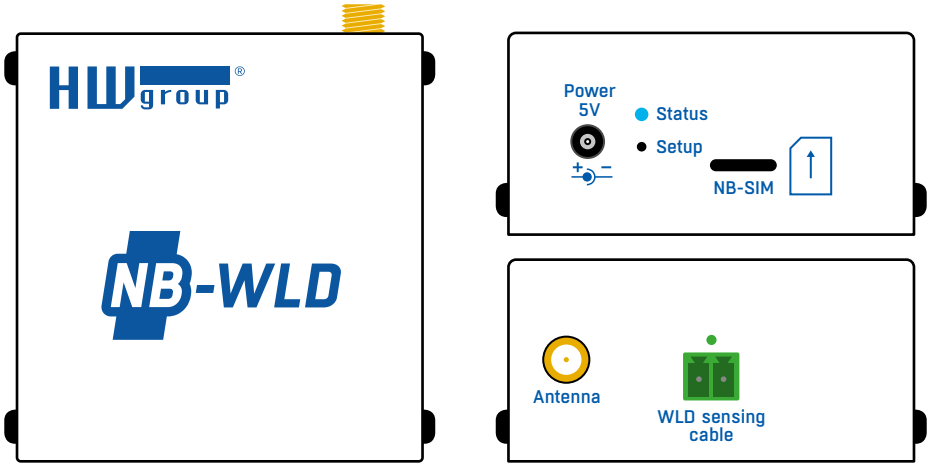

Water leak detector with a moisture-sensing cable. Allows connecting 1 sensing cable of up to 65m length, or extend it by up to 20m.

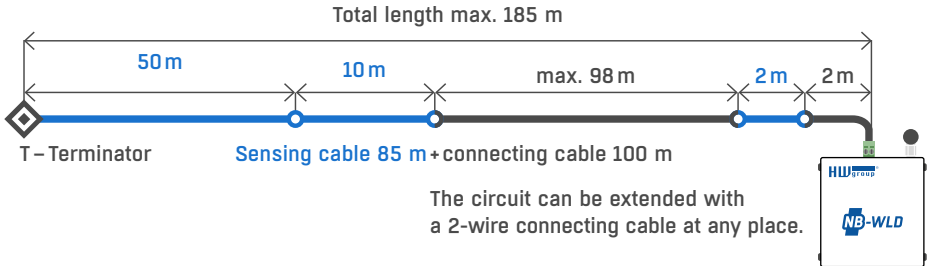

The flood detection is performed every 5 minutes and the estimated battery life are 4 years. If the cable is flooded or disconnected and the device is powered from an external adapter, the red LED lights up. The LED is inactive on battery power.

NB-2xOUT

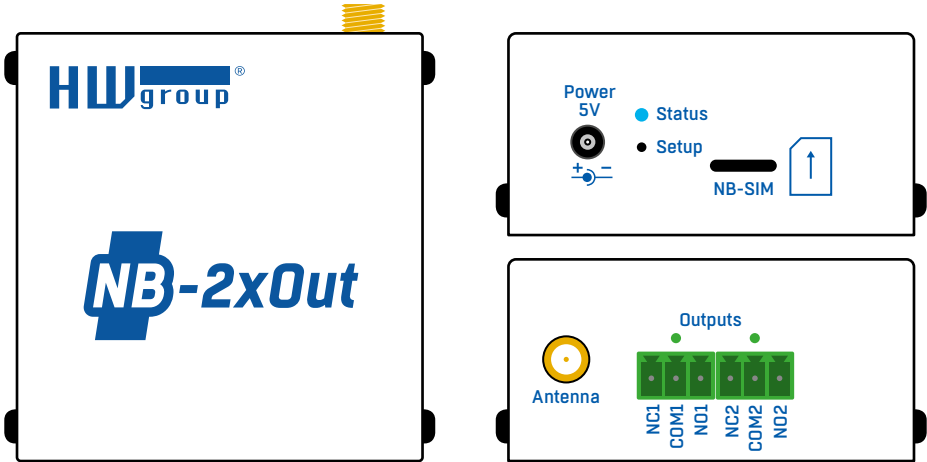

A module with 2 relay outputs controlled from the SensDesk portal over the NB-IoT network. To reduce consumption, the device features two latching relays. For increased reliability, the relays are energized repeatedly every 10 minutes. The device is not suitable for mobile applications.

On battery power only, the estimated battery life are 2 years.

When an output is closed and the device is powered from an external adapter, the respective yellow LED lights up. The LEDs are inactive on battery power.

Technical specifications

External sensors (NB-1Wire only)	
Port / connector	Port1, Port2 / RJ11 (1-Wire, 1-Wire UNI)
What can be connected	2 external sensors. One combined temperature + humidity sensor can be also connected
Sensor types	Only sensors by HW group s.r.o.
Sensors / distance	4 values, max. 2 probes per port (max. 60m total length per port)
Alarm LED	Alarm Port1 – Alarm SENS – lights up if the sensor is in alarm

WLD cable (NB-WLD only)	
Type	Moisture sensing cable
Connector	Terminal block
Sensor states	0 = OK, 1 = Flooded, 2 = Cable disconnected
Sensing cable length	Up to 65 m
Cable extension	May be extended by at most 20m, AWG 24
LED	1× red – activated or cable disconnected – on external power only

DI – Dry Contact Inputs (NB-2xIN only)	
Port / connector	I1, I2 / terminal block ø2 mm
Type	Digital Input (supports NO/NC Dry contact)
Sensitivity	1 (On) = 0 – 500 Ω
Max. distance	Up to 10 m
Counter sensitivity	20 ms
LED	2× green – input contact closed – on external power only
Pulse counter	External power required for reliable pulse counting – S0 = min 5V / 2–10 mA.

Relay outputs (NB-2xOUT only)	
Type	Latching (bipolar) relay
Connector	Terminal block
Rating	Max. 500 mA at 125 V AC, 1 A at 30 V DC
LED	2× green – output contact closed – on external power only

NarrowBand	
Supported bands	B1 / B2 / B3 / B4 / B5 / B8 / B12 / B13 / B17 / B18 / B19 / B20 / B25 / B26* / B28 / B66
Certifications	<p>Carrier: Vodafone (Global) Deutsche Telekom / Telefónica* (Europe) AT&T / T-Mobile / Verizon* / Sprint* (North America) LGU+* (South Korea) SoftBank / NTT DOCOMO* (Japan) Telstra* (Australia)</p> <p>Regulatory: GCF (Global) CE (Europe) FCC / PTCRB (North America) IC (Canada) KC (South Korea) NCC (Taiwan) JATE / TELEC (Japan) RCM (Australia) NBTC (Thailand) IMDA (Singapore)</p> <p>Others: RoHS ATEX (Europe)</p>
Output power	23 dBm ±2 dB
Sensitivity	129 dBm
Antenna	External, SMA
Supported protocols	IP: UDP/IP (CoAP)

* Under development

Power	
Supply voltage	5 VDC / 120 mA
Connector	Jack Ø3.5x1.35 / 10 mm
Battery	Alkaline 3V model CR123A

Common LEDs	
Status	Blue – communicating in the NB-IoT network (on), connecting to the network (flashing), reading sensors (brief flash)

Button	
Setup	Short press – sensor detection, immediate upload of values Pressed for longer than 10 s – reset to factory defaults

Miscellaneous	
Operating temperature	-10 to +60 °C (for the device – sensors may support different operating ranges)
Dimensions / weight	67×78×33 mm / 250 g
Electromagnetic radiation	CE / FCC Part 15, Class B
EMC	EN 55022, EN 55024, EN 61000

Mechanical dimensions

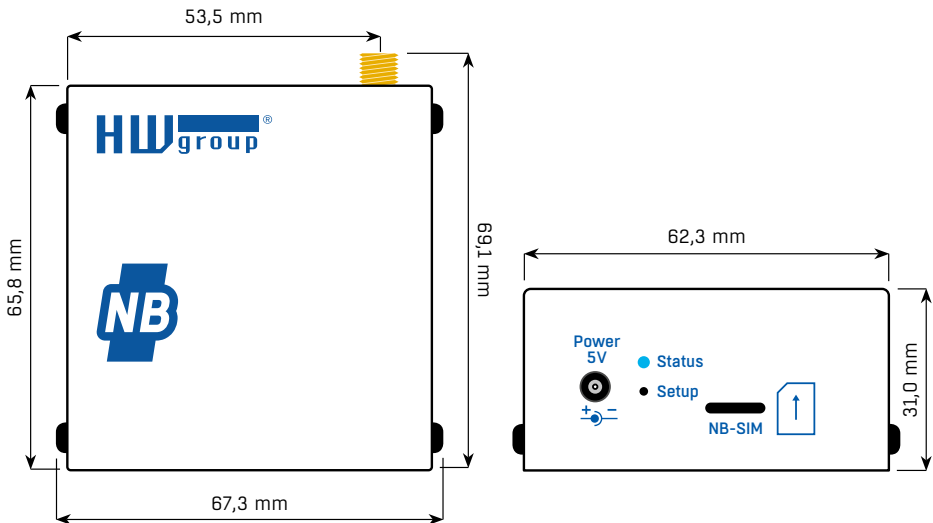

More monitoring devices by HW group



Poseidon2 4002

Designed for demanding monitoring applications, such as in data centers and industrial settings.



Poseidon2 2468

Remote monitoring of temperature, humidity and other sensors. Industrial version.



Poseidon2 3266/3268

Basic unit for monitoring temperature, humidity, and other sensors over the network.



Ares 10/12

Remote environment monitoring at any place with GSM coverage.



SD family

Simple devices for the monitoring of temperature, humidity, voltage, current, and other parameters.



WLD2

Quad water leak detector with WiFi and Ethernet.



HW group s.r.o.
Rumunská 26/122
Prague, 120 00
Czech Republic

Phone: +420 222 511 918
Fax: +420 222 513 833

www.HW-group.com

manual version: 1.0.3